

VC Series



Volume Control Dampers

- Roll formed steel blades with three material options
- DW144 compliant
- Class C case leakage on all models
- Flanged models with 65mm deep mechanically fixed casings
- Rectangular spigotted models with 85mm fully welded case
- Circular spigotted models with 70mm fully welded case
- Suitable for vertical and horizontal ducted systems.



VC Series

Volume Control Dampers – Product Description and Features



Introduction

Designed primarily to balance airflows in low to medium velocity H&V systems, the VC Series Volume Control Damper can also be used to perform actuated control functions where low closed blade leakage is not a requirement. Flanged models have mechanically fixed 65mm deep casings, providing a robust, lightweight construction. All models are suitable for DW144 pressure classes A, B & C.

Features

- Galvanised mild steel casing as standard
- 50mm wide roll formed galvanised or stainless steel blades
- Opposed blade action as standard with parallel action available on request
- Four casing options
- VC Series dampers can be installed in the vertical or horizontal position.
- Steel linkage located out of the airflow
- Sizing capability in 1mm increments; 100mm square/rectangular to 1000mm square/rectangular and from 100mm diameter to 1000mm diameter
- Flanged models with 65mm deep mechanically fixed casings and 30mm flanges with universal corner fixing slots
- Rectangular spigotted models with 85mm fully welded case
- Circular spigotted models with 70mm fully welded case
- Nylon spindles running in extruded punch formed bearings
- Comprehensive control options.
- Flanged Clinch corner providing a strong jointing system without the need for welding.
- Weldless flanged case joints provide a smooth surface each side of the damper that allows connecting ductwork systems to achieve high performance seals for the designed ducting pressure class.
- Circular spigot cased models are fully welded
- Clinch blade system provides smooth lines that minimises air turbulence and low generated noise.
- The drive linkage system provides low friction blade operation
- Fitted cover on drive side ensures migrating dust and dirt is eliminated from the blade bearings and drive mechanism, whilst still allowing ducting cleats to be used.
- Non drive side has sealed nylon bushes
- For non-standard '50mm' heights + 10mm to 49mm, a bottom landing angle will be fitted

Blade Details

The 50mm wide roll formed mild steel galvanised or stainless steel blades (430 and 316L stainless steel) are fitted with composite end caps and 12.5mm diameter nylon spindles.

All models are available with opposed blade action as standard, with parallel blade action available on request.



Specifications and Testing

- All case models suitable for Class C of DW144
- Conforms to Eurovent 2/2 classes A-C
- Performance tested for pressure loss and case and blade leakage

Flangefit

W x H = 100mm to 1000mm square

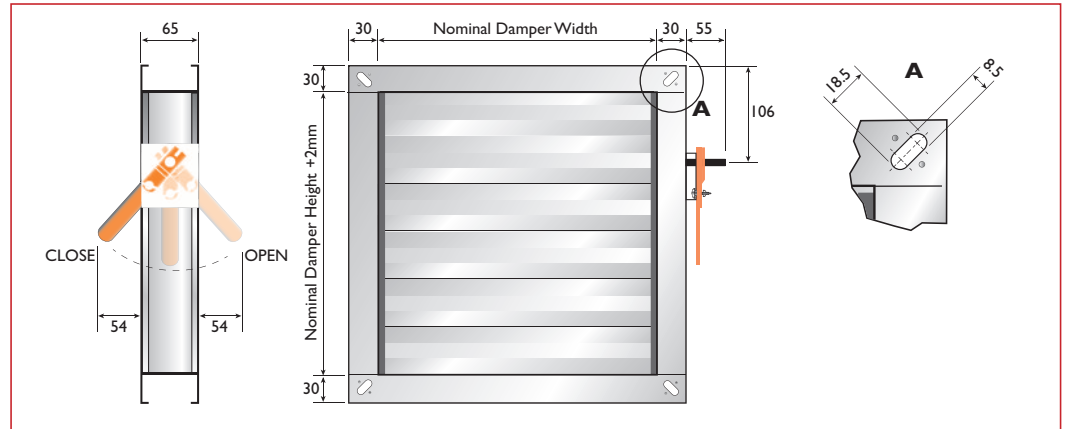

Spigotfit

W x H = 100mm to 1000mm square

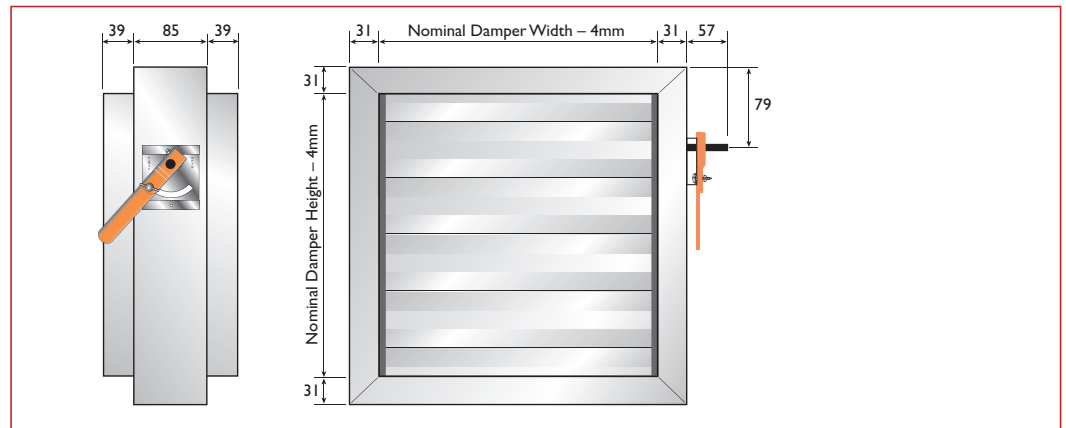

Circular Spigotfit

D = 100mm to 1000mm diameter

* = 41mm (100-350mm dia.)
55mm (351-1000 dia.)

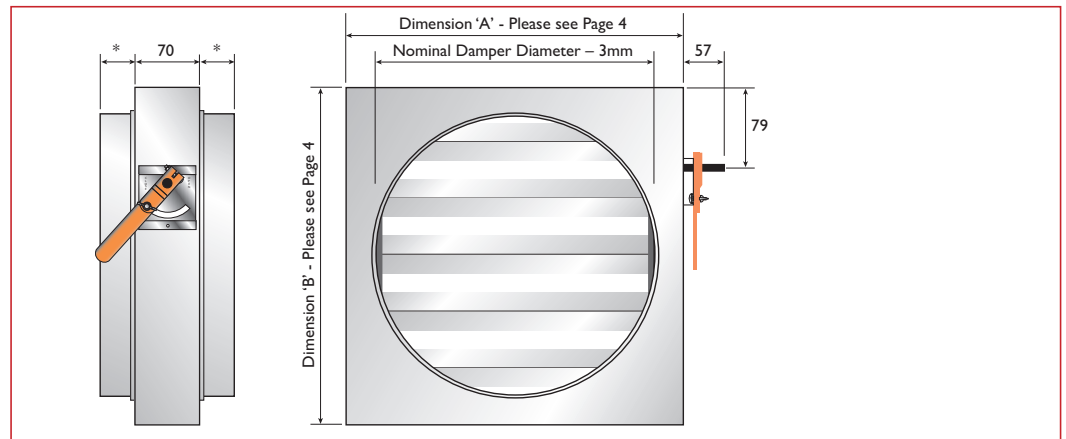

Flat Oval Spigotfit

W x H = 100mm to 1000mm spigots

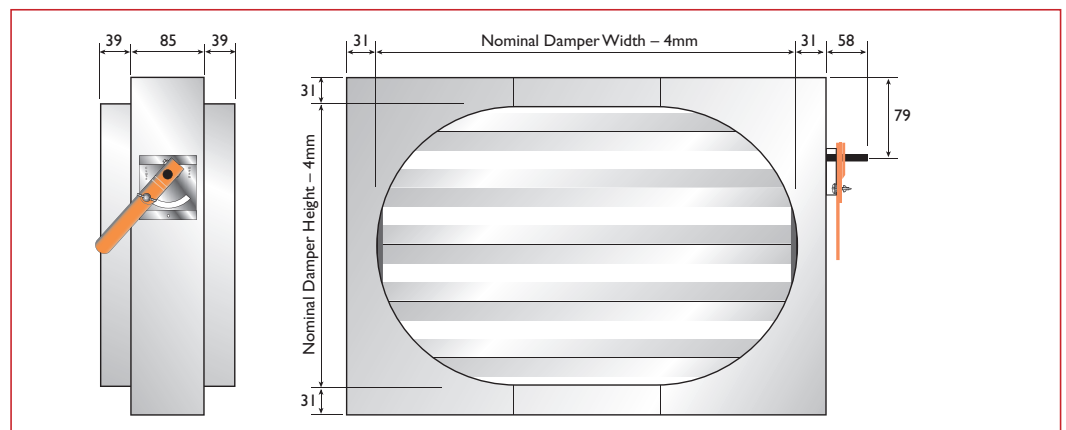

Dimensions

Nominal Damper Diameters 100mm - 1000mm

Width (Dimension 'A') and Height (Dimension 'B') are Nominal Damper Diameter +57mm.

Except in the case of:

Nominal Damper Diameter 160mm

Width (Dimension 'A') and Height (Dimension 'B') are Nominal Damper Diameter +47mm.

Nominal Damper Diameter 315mm

Width (Dimension 'A') and Height (Dimension 'B') are Nominal Damper Diameter +42mm.

Nominal Damper Diameter 355mm

Width (Dimension 'A') and Height (Dimension 'B') are Nominal Damper Diameter +52mm.

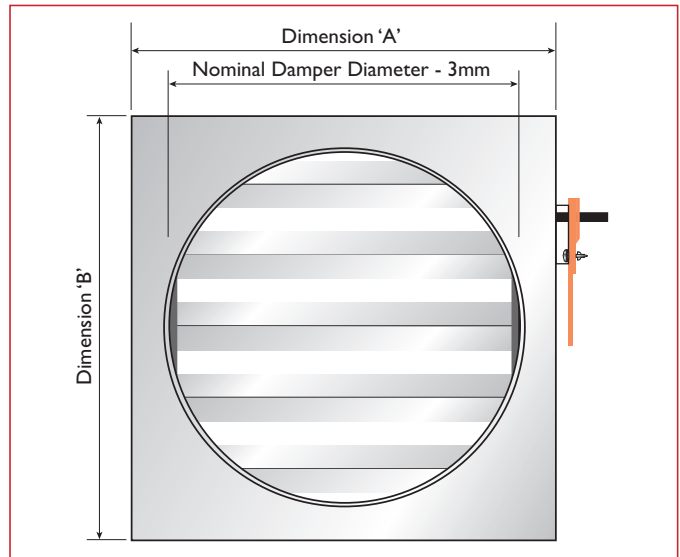

Multiple Assemblies

Illustrated opposite are several variants of multiple section units. Where sizes exceed 1000mm square, multi-section units will be supplied.

All multiple units are shipped as individual sections for site assembly. Care must be taken not to drill or rivet into the damper linkage mechanism and stub shafts when fixing the provided joining strips.

Joining strips can be supplied pre-drilled upon request.

It is recommended that for sizes greater than 1000mm in width or height, the HD Series Heavy Duty Damper is used.

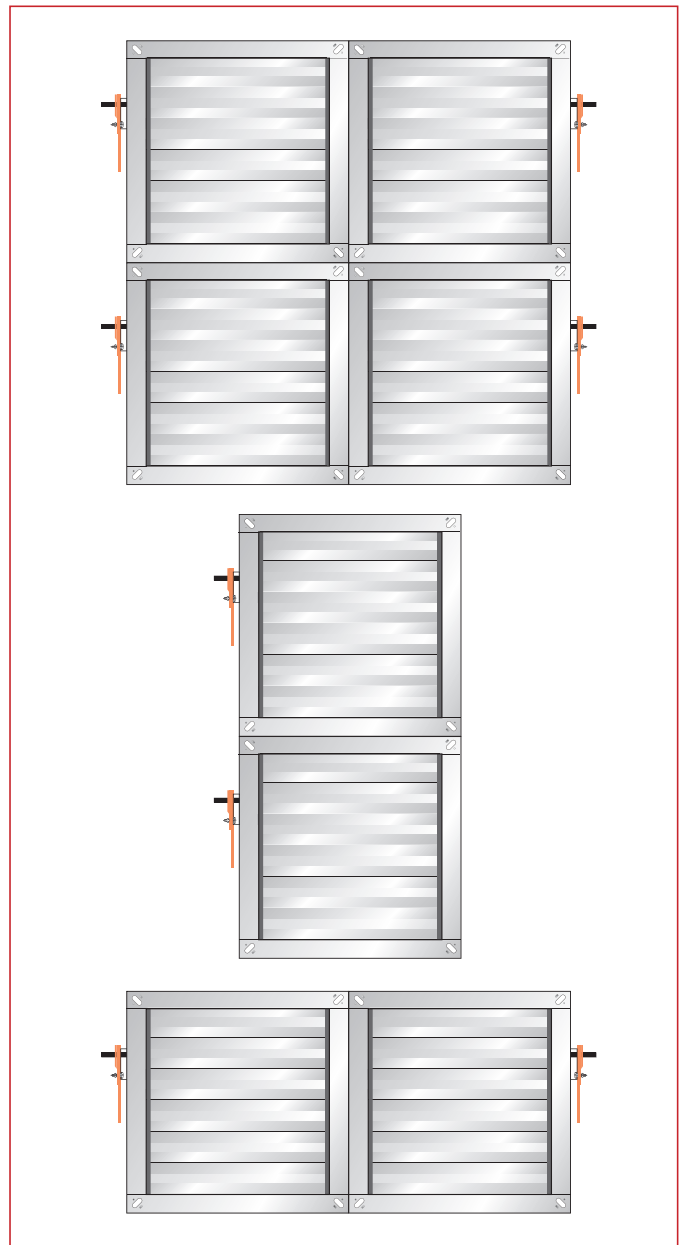

Maintenance

BSB VC Series Dampers are designed for installation within normal dry filtered air systems. A programme of planned inspections should be carried out to include full operational checks, correct interface and function of any controls and control systems.

As a guide, dampers should be inspected annually and more frequently if exposed to fresh air intakes and/or inclement and dusty conditions.

Any application involving corrosive and/or aggressive hostile environmental conditions (e.g. swimming pools and coastal applications) may invalidate our warranty and should be referred to BSB Sales Office.

Option H Hand Control

BSB's unique hand lockable quadrant is supplied complete from the factory.

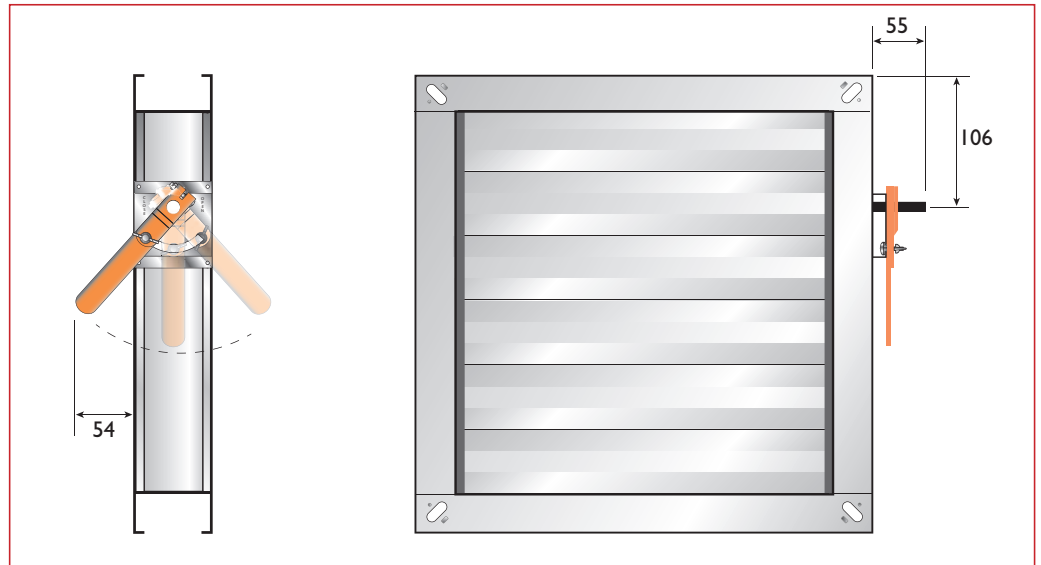

Option E Extended Spindle

When the specification requires the VC Series Damper to be motorised, BSB supplies the damper with a 12.5mm diameter drive spindle, 55mm in length.

An optional actuator bracket can be supplied at extra cost.

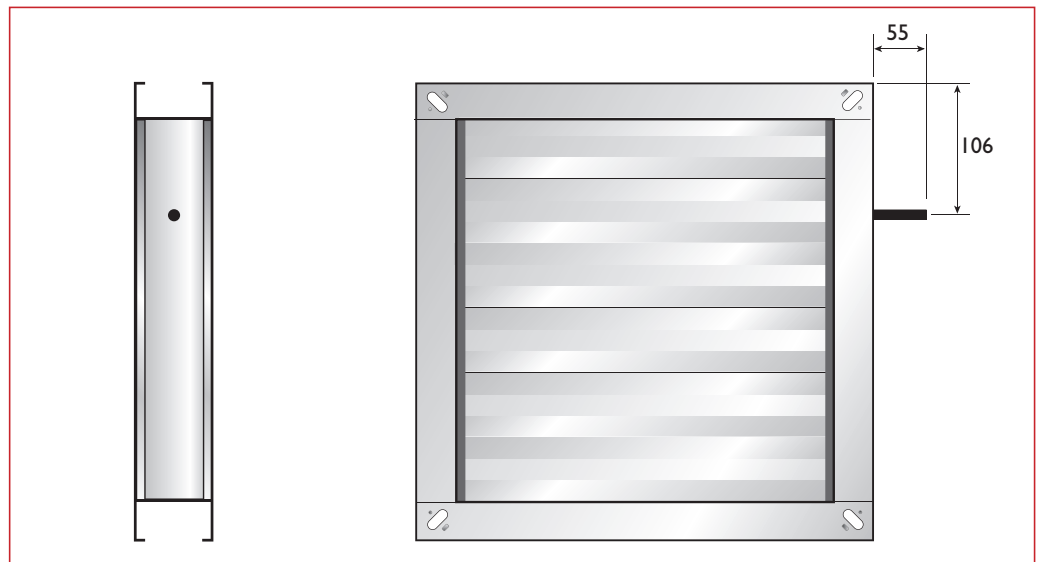

Option M Electric Motor

The VC Series Damper can be supplied with motors having the following torque outputs:

5Nm up to 600mm square or 600mm diameter

10Nm from 601mm to 1000mm square or diameter

For additional technical details, please contact BSB's sales office.

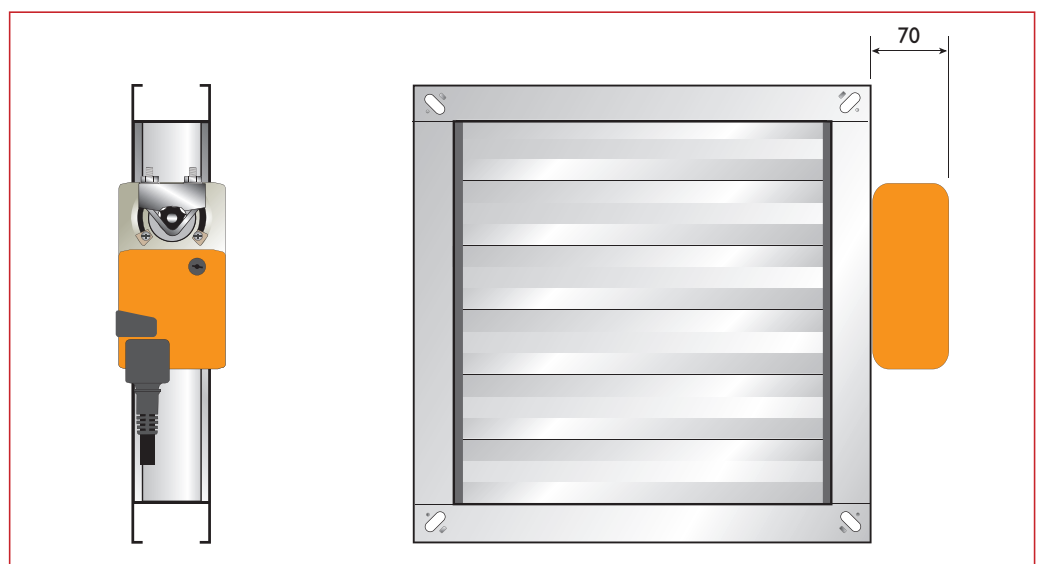

Weight Chart

Damper Height (mm)	Damper Width (mm)									
	100	200	300	400	500	600	700	800	900	1000
100	1.0	1.3	1.7	2.1	2.4	2.8	3.1	3.5	3.8	4.2
200	1.5	1.9	2.4	2.9	3.3	3.8	4.2	4.7	5.2	5.6
300	2.0	2.5	3.1	3.7	4.2	4.8	5.4	5.9	6.5	7.0
400	2.5	3.1	3.8	4.5	5.1	5.8	6.5	7.1	7.5	8.5
500	3.0	3.7	4.5	5.3	6.1	6.8	7.6	8.4	9.1	9.9
600	3.5	4.3	5.2	6.1	7.0	7.8	8.7	9.6	10.5	11.3
700	4.0	4.9	5.9	6.9	7.9	8.9	9.8	10.8	11.8	12.8
800	4.5	5.5	6.6	7.7	8.8	9.9	11.0	12.0	13.1	14.2
900	5.0	6.2	7.3	8.5	9.7	10.9	12.1	13.3	14.5	15.7
1000	5.5	6.8	8.0	9.3	10.6	11.9	13.2	14.5	15.8	17.1

The above weights (in kilograms) are for flanged models. For spigot models multiply by 1.5

Performance Characteristics

Pressure Loss

VC Series 600mm square

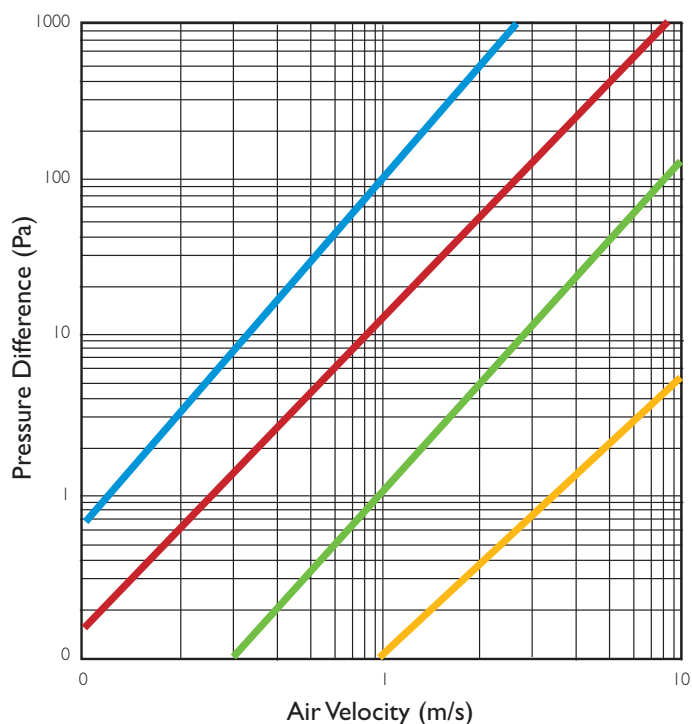

- 67.5° from Open
- 45° from Open
- 22.5° from Open
- Fully Open

Case Leakage

VC Series 600mm square

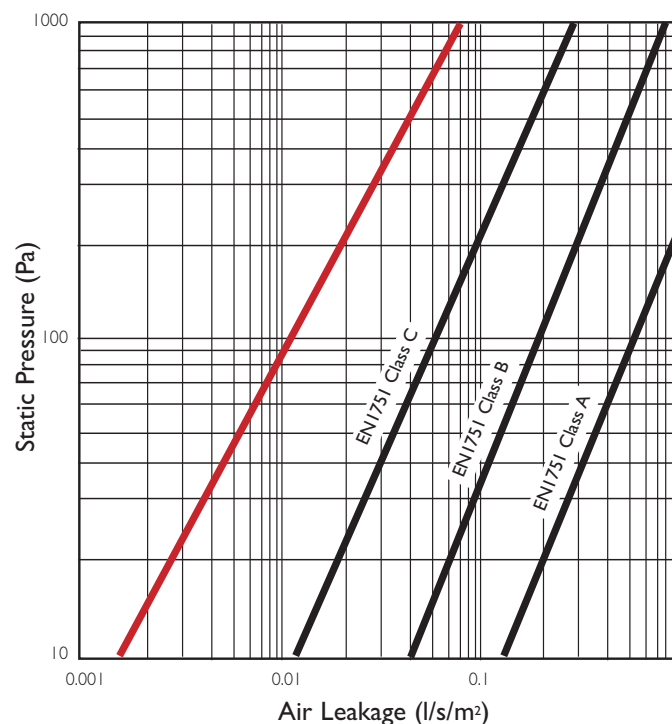

Material Specification

Casing

1.2mm thickness galvanised mild steel to BS EN 10346. DX 51D Z275.

Blades

0.5mm thickness galvanised mild steel to BS EN 10346. DX 51D Z275.

Blade Cap

Injection moulded from glass filled Nylon 66.

Drive Bearings

Injection moulded from glass filled Nylon 66.

Drive Linkage Bars

1.5mm thickness galvanised mild steel to BS EN 10346. DX 51D Z275.

Drive Spindle

Dampers fitted with a handle will have a plastic injection moulded spindle made from Nylon 66. Dampers that have an actuator or extended spindle will have a spindle made from die-cast Zinc alloy ZL3 BS EN 12844.

Handle

Injection moulded from Nylon 66

Quadrant Handle Bracket

1.2mm thickness galvanised mild steel to BS EN 10346. DX 51D Z275.

Rivets

Rivets used meet European standards.

Sealant

Good quality silicone sealant.

Operating Temperature

0°C to +70°C

Optional Material Specification

Casing

- 1.2mm thickness Specification 1.4016 (430) stainless steel to BS EN 10088-2.
- 1.2mm thickness Specification 1.4404 (316L) stainless steel to BS EN 10088-3.

Options

Blades

- 0.5mm thickness Specification 1.4016 (430) stainless steel to BS EN 10088-2.
- 0.5mm thickness Specification 1.4404 (316L) stainless steel to BS EN 10088-2.

Drive Linkage Bars

- 1.5mm thickness Specification 1.4016 (430) stainless steel to BS EN 10088-2.
- 1.2mm thickness Specification 1.4404 (316L) stainless steel to BS EN 10088-2.

Handle Quadrant Plate

- 1.2mm thickness Specification 1.4016 (430) stainless steel to BS EN 10088-2.
- 1.2mm thickness Specification 1.4404 (316L) stainless steel to BS EN 10088-2.

Typical Tender/Specification Text

BSB's VC damper shall be provided for the balance and regulation of airflows within ducted air systems. The volume control dampers shall have 50mm wide roll formed steel blades rotating in extruded bearings. Blades shall have capped ends to reduce noise generation. Damper blade drive systems shall be outside of the air stream and covered to prevent the ingress of dust and debris and sealed to achieve case leakage Classes A, B & C of DW144.

VC volume control dampers shall meet duties up to 1000Pa and 12m/s.

Manually settable volume control dampers shall be supplied with a factory fitted quadrant that allows infinite adjustment of air flow.

Volume control dampers suitable for motorisation shall be fitted with an extended spindle. The extended spindle shall be easily convertible to quadrant control for manual setting without the need for any specialist tools or modifications if required.

VC Series

Volume Control Dampers – Ordering Codes



VC F G - H

VC Series Volume Control Damper

Model

- F** Flangefit
- S** Rectangular/Square Spigotfit
- C** Circular Spigotfit
- O** Flat Oval Spigotfit

Blade Material

- G** Galvanised Steel Airfoil Blades
- S** Stainless Steel Airfoil Blades (State Grade)

Control Options

- H** Hand Control
- E** Extended Spindle
- M** Electric Motor (state voltage and model)
For Pneumatic option, please refer to HD model

Air, Fire and Smoke Control Products in the Range:



For full details of the complete Product Range, please refer to our individual product brochures, sales office or website.



BSB Engineering Services Limited

Unit 56, Trinity Trade Centre, Mill Way, Sittingbourne, Kent ME10 2PD, UK • Tel: +44 (0)1795 422609 • Fax: +44 (0)1795 429543

For purchase orders and order related enquiries, please email: orders@bsb-dampers.co.uk

For pricing, technical and general enquiries, please email: enquiries@bsb-dampers.co.uk

Website: www.bsb-dampers.co.uk • A member of the Maico group

BSB Engineering Services Ltd. reserves the right to modify or withdraw any specification without prior notice that may result from continuous product development. The information contained within this brochure is correct at the time of going to press. (VC-10-2016)

